



WATER
Commercial – Industrial
Water Purification

**Service Deionizer
Model 724-FG
Laboratory 0.5 Ft³**

The **Model 724-FG** deionizer is the most compact service unit in our float. It is particularly useful for low volume, high purity deionized water uses such as laboratories.

*Cal Water service deionizers are regenerated in a **computer controlled** regeneration plant. Computer control provides more consistent quality at lower cost, while storing all regeneration results electronically. This stored data is available in graph and tabular form for customer QC reports.*

FEATURES



- **724-FG** Mixed bed deionizers are single units containing both cation and strong base anion resins mixed in a single vessel. Mixed beds produce the highest quality water that typically ranges from 200,000 to 18,000,000 ohms/cm³.
- The Cal Water 724-FG portable exchange service deionizer is a corrosion-proof, FRP fiberglass tank with an inert ABS plastic liner and a rubber base. Both the inlet and outlet hardware of the 724 deionizer tank are made of the same ABS plastic as the tank liner.
- The 724-FG deionizer contains half a cubic foot of water purification media.
- Every 724-FG deionizer comes equipped with a red-green water quality indicator as standard equipment. (Temperature compensated TDS meters are available as options.)

System	Type	FlowRate	Ft ³	Capacity		Water Quality	Water Quality
		GPM	Resin	Grains	Gallons*	In Ohms/cc	Microsiemens
724-FG	Mixed Bed	2	0.5	3,750	214	200K- 10 meg	5 - 0.1

**724-FG
Mixed Bed Deionizer**

*Gallon capacities are based on 300 ppm feed. **Warranty:** Cal Water guarantees labor and material for 1 year from the date of an installation. In case of defect in equipment, labor, material or service, Cal-Water's sole responsibility is for the replacement or repair of the defect and cannot be held liable for losses of any kind.

Cal Water, 1961 Petra Lane, Placentia, CA 92870
(800) CAL-WATER (800) 225-9283
FAX: (714) 792-0794
Web Page / Email: www.cal-water.com

Orange County (714) 835-7878
Los Angeles County (323) 663-8335
San Diego County (858) 457-8411

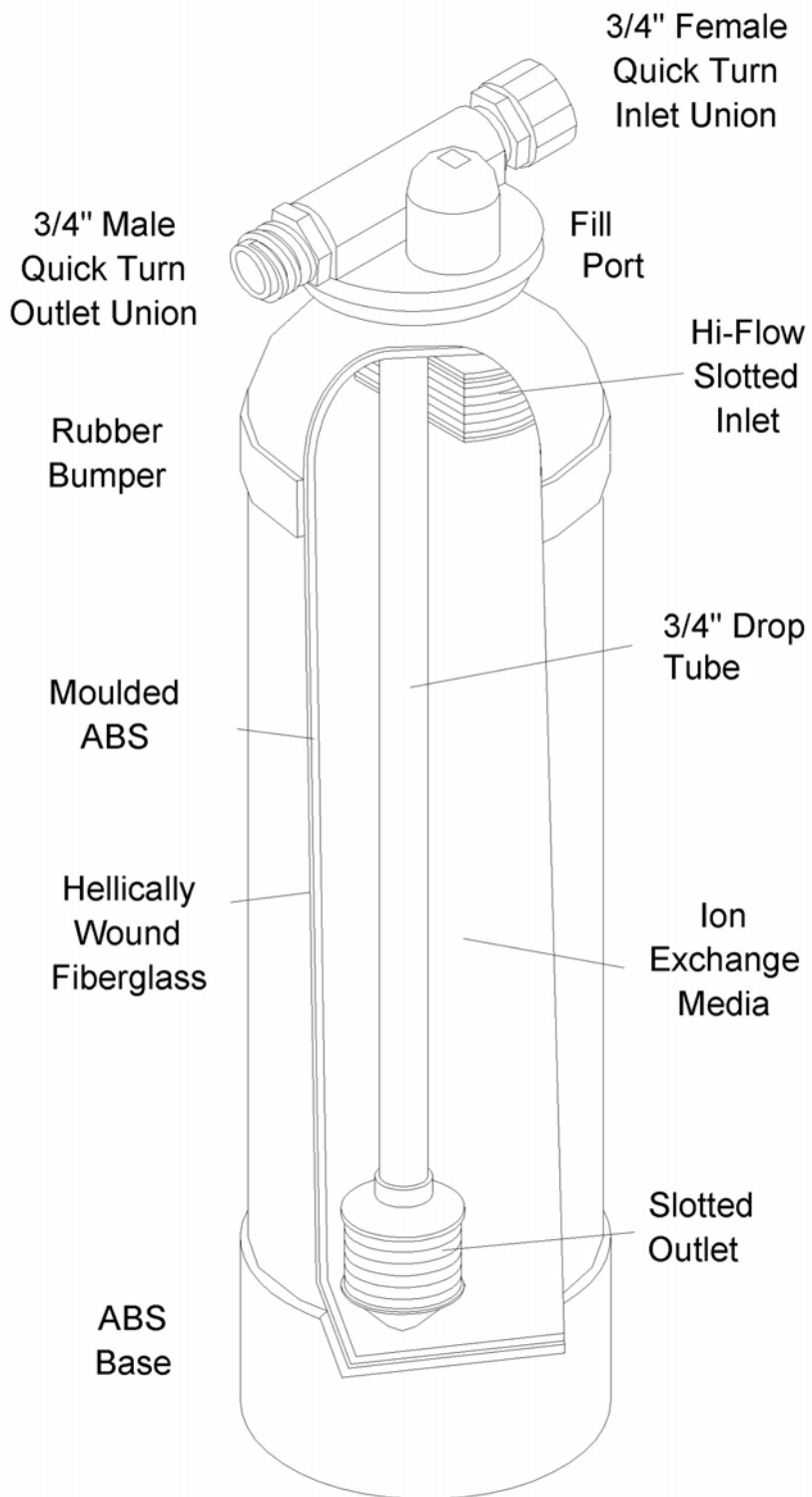

724-FG Series
Service Deionizer Tank